

Z 4500/...

Mat.: WAS (≈ 1.2343)
gehärtet und nitriert / hardened and nitrided / trempé et nituré

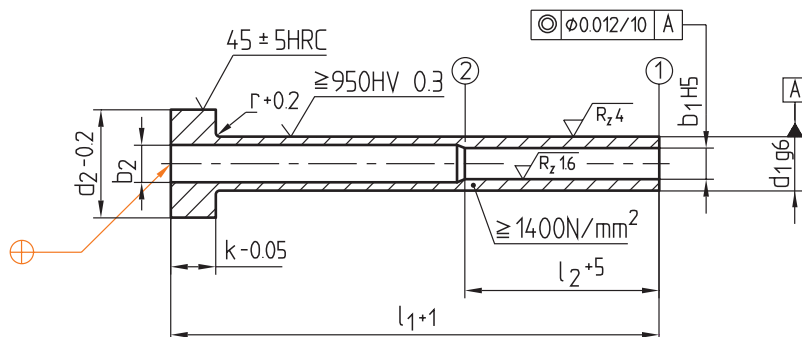

► Info



r	b ₂	d ₂	k	l ₂	d ₁	b ₁	l ₁	Nr./No.
0,3	1,3	5	2	25	2,5	1	71	Z 4500/2,5/1 x 71
							80	80
							90	90
							100	100
							100	100
0,3	1,4	5	2	25	2,5	1,1	71	Z 4500/2,5/1,1 x 71
							80	80
							90	90
							100	100
0,3	1,5	5	2	25	2,5	1,2	71	Z 4500/2,5/1,2 x 71
							80	80
							90	90
							100	100
0,3	1,6	5	2	25	2,5	1,3	71	Z 4500/2,5/1,3 x 71
							80	80
							90	90
							100	100
0,3	1,7	6	3	25	3	1,4	71	Z 4500/3 /1,4 x 71
							80	80
							90	90
							100	100
0,3	1,8	6	3	25	3	1,5	71	Z 4500/3 /1,5 x 71
							80	80
							90	90
							100	100
							100	100
0,3	2	6	3	36	3	1,6	71	Z 4500/3 /1,6 x 71
							80	80
							90	90
							100	100
							100	100
							112	112
							125	125
							140	140
							140	140
							140	140

r	b ₂	d ₂	k	l ₂	d ₁	b ₁	l ₁	Nr./No.
0,3	2	6	3	36	3	1,7	71	Z 4500/3 /1,7 x 71
							80	80
							90	90
							100	100
							100	100
0,3	2,1	6	3	36	3	1,8	71	Z 4500/3 /1,8 x 71
							80	80
							90	90
							100	100
0,3	2,2	6	3	36	3	1,9	71	Z 4500/3 /1,9 x 71
							80	80
							90	90
							100	100
0,3	2,3	7	3	36	3,5	2	71	Z 4500/3,5/2 x 71
							80	80
							90	90
							100	100
							100	100
0,3	2,8	8	3	36	4	2,5	50	Z 4500/4 /2,5 x 50
							56	56
							63	63
							71	71
							80	80
							90	90
							100	100
0,3	2,8	8	3	36	4,5	2,5	100	Z 4500/4,5/2,5 x 100
							112	112
							125	125
							125	125
							140	140

Z 4500/...

Mat.: WAS (≈ 1.2343)
 gehärtet und nitriert/hardened and nitrided/trempé et nitruré



► Info

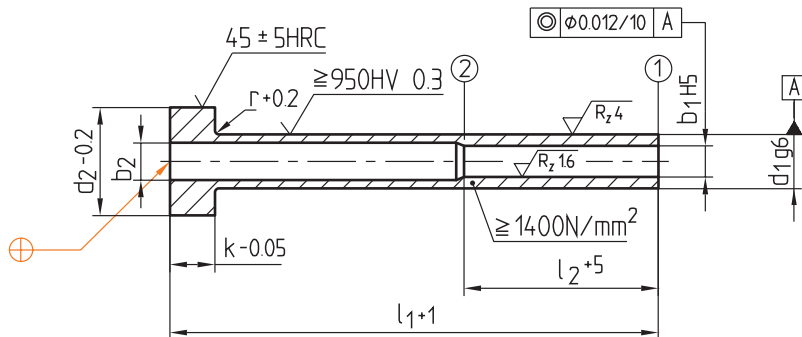

r	b ₂	d ₂	k	l ₂	d ₁	b ₁	l ₁	Nr./No.
0,3	3	8	3	50	4,5	3	50	Z 4500/4,5/3 x 50
				45			56	56
				63			63	
				71			71	
				80			80	
				90			90	
				100			100	
				112			112	
				125			125	
0,3	3,3	10	3	45	5	3	100	Z 4500/5 /3 x 100
							112	112
							125	125
							140	140
							160	160
							180	180
							200	200
							224	224
							250	250
0,3	3,8	10	3	45	5	3,5	56	Z 4500/5 /3,5 x 56
							63	63
							71	71
							80	80
							90	90
							100	100
							112	112
							125	125
							140	140
0,3	3,8	10	3	45	5,5	3,5	112	Z 4500/5,5/3,5 x 112
							125	125
							140	140
							160	160
							180	180
							200	200
0,3	4,3	10	3	45	5,5	4	56	Z 4500/5,5/4 x 56
							63	63
							71	71
							80	80
							90	90
							100	100
							112	112
							125	125
							140	140

r	b ₂	d ₂	k	l ₂	d ₁	b ₁	l ₁	Nr./No.
0,5	4,3	12	5	45	6	4	112	Z 4500/6/4 x 112
							125	125
							140	140
							160	160
							180	180
							200	200
							224	224
							250	250
							280	280
0,5	5	12	5	45	7	4,5	112	Z 4500/7/4,5 x 112
							125	125
							140	140
							160	160
							180	180
							200	200
							224	224
							250	250
							280	280
0,5	5,3	12	5	45	7	5	56	Z 4500/7/5 x 56
							63	63
							71	71
							80	80
							90	90
							100	100
							112	112
							125	125
							140	140
0,5	5,8	14	5	45	8	5,5	112	Z 4500/8/5,5 x 112
							125	125
							140	140
							160	160
							180	180
							200	200
0,5	5,8	14	5	45	8	5,5	112	Z 4500/8/5,5 x 112
							125	125
							140	140
							160	160
							180	180
							200	200

This is trial version
 www.adultpdf.com

Z 4500/...

Mat.: WAS (≈ 1.2343)
gehärtet und nitriert / hardened and nitrided / trempé et nituré



► Info

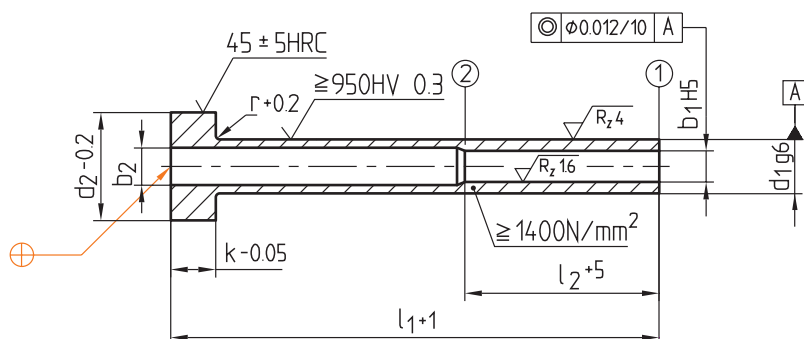

r	b ₂	d ₂	k	l ₂	d ₁	b ₁	l ₁	Nr./No.							
0,5	6,5	14	5	45	9	6	125	Z 4500/ 9/ 6x125							
							140	140							
							160	160							
							180	180							
							200	200							
							224	224							
							250	250							
							280	280							
							0,5	7,5	16	5	45	10	7	125	Z 4500/10/ 7x125
140	140														
160	160														
180	180														
200	200														
224	224														
250	250														
280	280														
0,5	8,5	18	5	45	11	8								63	Z 4500/11/ 8x 63
							71	71							
							80	80							
							90	90							
							100	100							
							112	112							
							125	125							
							140	140							
							0,8	9,3	20	7	45	12	9	63	Z 4500/12/ 9x 63
														71	71
														80	80
90	90														
100	100														
112	112														
125	125														
140	140														
0,8	10,5	22	7	50	14	10	140	Z 4500/14/10x140							
							160	160							
							180	180							
							200	200							
							224	224							
							250	250							
							280	280							

r	b ₂	d ₂	k	l ₂	d ₁	b ₁	l ₁	Nr./No.							
0,8	12,5	22	7	50	16	12	140	Z 4500/16/12x140							
							160	160							
							180	180							
							200	200							
							224	224							
							250	250							
							280	280							
							1	16,5	26	7	50	20	16	140	Z 4500/20/16x140
														160	160
180	180														
200	200														
224	224														
250	250														
1	20,5	32	10	50	25	20	140	Z 4500/25/20x140							
							160	160							
							180	180							
							200	200							
							224	224							
							250	250							
							280	280							
315	315														

This is trial version
www.adultpdf.com